



EPIperformance.com

8273 Industrial Park Road •Baxter, MN 56425 • (218) 829-6036 • Fax (218) 829-1685

## POLARIS CLUTCH KIT INSTRUCTIONS

**Model: 500 SPORTSMAN HO CARB 4x4 2006/08-09 (STOCK TIRES) Part #: WE415082**

**Kits designed for Stock motor and stock exhaust at 0-3000 feet elevation.**

ATV's can be dangerous. EPI has no control over the use of any part. EPI expects the customer to exercise good judgment as to the proper selection, installation, use and maintenance of any part. EPI assumes no responsibility for damage or injury of any kind because of misuse, improper installation and improper application of any parts in any way by any person. Contact your local dealer to schedule installation of this clutch kit if you are not a qualified ATV mechanic.

**This product is NOT to be installed on any ATV that will be used by any person under the age of 16.**

### **TOOLS NEEDED TO INSTALL CLUTCH KIT**

- 3/8, 7/16, 1/2 socket and wrench
- 5/8 socket
- Torque wrench
- Snap ring pliers
- Phillips screwdriver
- Side cutters
- 1/8 Allen wrench
- Primary Clutch Puller (EPI part # PCP-1)

### **ENGAGEMENT**

- 21-2,300 Rpm's

1. Remove the key from the ignition. Remove the left side foot rest by unbolting it from the fenders and frame. Remove the zip ties or clamps on the vent hose coming from the top of the clutch cover. On some models you might have to remove the seat and the left side body panel between the front and rear fenders to gain access to the vent tube. Be careful not to damage the rubber boot when cutting the zip ties.
2. Using a screwdriver, loosen the clamp that holds the vent hose on the top of the clutch cover. Next remove the clutch cover bolts. Note the length of the bolts and their location. Some models might have a little metal clamp at the rear of the cover that needs to be removed, simply take a flat tipped screwdriver and pry the clamp off. Save the clamp because you will need to reuse it. Remove cover slowly being careful not to damage the gasket.
3. Remove the belt. You can remove belt by squeezing the belt together between the two clutches, this will allow enough slack in the belt to remove the belt. You can also twist the inside secondary (rear) clutch sheave towards the rear of the machine and then pull on the belt to get enough slack in the belt to remove it. The primary (front) clutch is pressed onto the crankshaft of the motor. Removal of the clutch is not required but does make the job much easier. To remove the clutch a special clutch puller is needed, this tool is available through EPI (part # PCP-1). Notice the "X" marked on the outside cover of the clutch, on the spider, and on the moveable sheave. These are alignment marks from the factory and must line up when you reassemble the clutch. If you are not removing the clutch see next step. To remove the clutch using a clutch puller remove the large center clutch bolt (5/8 socket). You need to use a small bar or large screwdriver and stick it through the clutch to stop the clutch from rotating while you loosen the center bolt. Remove the center bolt, washers, and any spacers that are there. Thread the clutch puller in by hand and tighten until the clutch pops off the shaft, you will need to hold the clutch from rotating. Place clutch on a clean work surface and remove clutch puller.
4. If you are not pulling the primary clutch off the machine OR if you already have the clutch off the machine, remove the six outside bolts from the cover. Next remove the center bolt allowing the cover and spring to be removed (this bolt is already removed if clutch is off the machine).
5. With the spring removed you can change the weights. Using a 1/8" Allen wrench and a 3/8" wrench or socket remove the bolt holding the weight in the clutch. Replace the stock weight with the weight included in the clutch kit and install the bolt and nut. Repeat the same process for the other two weights.
6. It is a good idea to clean your clutches. Using a clean rag and a contact/brake cleaner that **DOES NOT** leave an oily film or residue clean all areas of the clutch except on the bushings. Cleaning the clutch bushings with a cleaning solvent can cause premature wear. This applies to both clutches.

7. Install the **EPI** primary spring. Make sure the spring fits flat into the clutch at both ends. Install the cover plate making sure the "X" lines up. Tighten the six outside cover bolts evenly so the cover goes on straight to prevent bushing damage. Install the center clutch bolt and torque to 45-47 ft/lbs.
8. Remove the secondary (rear) clutch by removing the center clutch bolt and pulling towards you. The clutch should slide off the splined shaft. If the clutch sticks on the shaft spray some penetrating fluid on the shaft to help free it. If it still doesn't come off, you will need to order a secondary clutch puller (EPI part #SCP-1). When the clutch does come off pay attention to the shims behind the clutch on the shaft. These shims effect the clutch alignment, if they slide off the shaft be sure to put them back on.
9. Place the clutch face down so the snap ring is facing up. Push down on the helix to take the pressure off the snap ring and remove the snap ring. The helix and spring can now be taken out of the clutch. **CAUTION the helix will have spring tension on it and can pop up and out of the clutch when snap ring is removed.**
10. Apply a thin layer of grease on the splined hub of the EPI helix. Check to see if the spring fits into the necessary holes. Some models may need to have a 1/4" drill bit to make the current holes larger so the spring will properly seat in the hole. Install the EPI secondary spring in the    hole in the helix and the    hole in the clutch. Align the helix on the splined shaft and compress about halfway down. While holding the helix and the bottom half of the clutch from moving, turn the top half of the clutch counterclockwise approximately a 1/3 of a turn so the plastic buttons in the clutch rotate past the next ramp on the helix. Push the helix down and install the snap ring.

	Helix	Moveable Sheave	Spring Tension
	2	- 1	Heavy
	2	- 2	
Spring Position	1	- 1	↑
	2	- 3	↓
	1	- 2	
	1	- 3	Soft

11. Install the secondary clutch onto the machine and torque bolt to 15 ft/lbs. Install the belt so the words read from left to right. Rotate the belt backwards to reset the clutch so the belt sits towards the outside of the secondary clutch all the way around.
12. Check for proper belt deflection. The belt should ride 1/16" to 1/8" outside of the secondary clutch. Belt deflection should be 1 1/8" to 1 1/4" between the clutches. Place a straight edge on top of the belt between the clutches. Push down lightly on the belt to remove slack in the belt. Measure from the bottom of the straight edge to the top of the belt (see diagram), this measurement is your belt deflection. If you belt is out of specification, you can change it by adding or removing shims between the secondary clutch sheaves. Add shims to increase belt deflection or remove shims to decrease belt deflection. One shim must always be between clutch sheaves at all times.

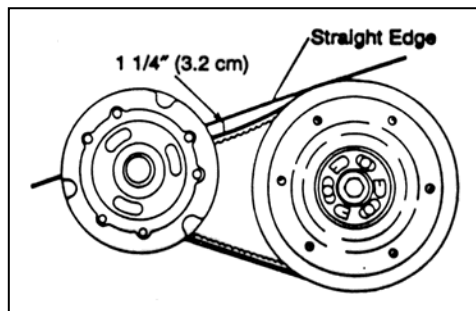

13. Install the plastic clutch cover making sure it seals properly. Install the small metal clamp back onto the rear of the clutch cover. Tighten the clamps or zip ties to seal the vent tube on top of the clutch cover. Install the side panel and seat. Install the foot rest and prepare to ride.
14. If after riding the machine something doesn't seem right, double check that the secondary clutch has been assembled correctly. If the machine seems stuck in high gear and not responsive chances are the secondary spring is in the wrong position or not wound up correctly, repeat steps 8 thru 13.
15. **EPI** is constantly testing our products. Sometimes there is a need to contact the user with new technical information. To ensure that you are receiving this information visit our web site **EPIperformance.com** to register your clutch kit.

**NOTICE:** Even with this clutch kit, you should be advised that using substantial throttle when the tires are not able to spin can cause the belt to slip and **damage may occur**. **EPI** recommends that the transmission be shifted into low range when high load, slower speed situations are encountered. **EPI is not responsible** for any damage to the drive belt or any other original equipment component.